

5000 | 5300 Series Electric Strikes



ASSA ABLOY

Experience a safer
and more open world

Installation Instructions

Product Components

- A 5000 | 5300 Electric Strike Body
- B Trim Enhancer & Screws (#4-40 x 1/8")
- C 12 & 24 Volt Plug In Connectors

Electrical Specifications

Electrical Ratings for Solenoid	Continuous Duty		Intermittent Duty*		
	12 VDC	24 VDC	12 VAC	16 VAC	24 VAC
Voltage	12 VDC	24 VDC	12 VAC	16 VAC	24 VAC
Resistance in Ohms	50	200	50	50	200
Amps	.24	.12	.24	.32	.12

Solenoids are rated at +/- 10% indicated value.
*10% max duty cycle (2 min. max on time)

Shall be powered by a UL 294 Class 2 Power Limited power supply or Listed Access Control units or ULC-60839-11-1: Grade 1 listed Access Control Units.

For inductive kickback protection, consider using with the HES 2005M3 SMART Pac® III or 2001M Plug-in Bridge Rectifier with built-in MOV (not evaluated by UL294/UL1034).

Minimum Wire Gauge Requirements		
Voltage	12 VDC	24 VDC
200 feet or less	18 gauge	20 gauge
200–300 feet	16 gauge	18 gauge
300–400 feet	14 gauge	16 gauge

Lengths based on round trip. The minimum permissible wire size to be used shall not be less than 26 AWG. Wiring methods shall be in accordance with the National Electrical Code (ANSI/NFPA70), local codes and the authorities having jurisdiction.

UL1034 Performance Levels	
Static Strength	1,500 lbs
Dynamic Impact	70 ft-lbs
Endurance	250,000 cycles

Suitable for outdoor use.

UL294 Performance Levels*	
Destructive Attack	Level I (No attack test)
Line Security	Level I (No line security)
Endurance	Level IV (100,000 cycles)
Standby Power	Level I (No secondary power source)

*Monitor options were not evaluated to UL294/UL1034/
ULC-60839-11-1: Grade 1. Indoor use.

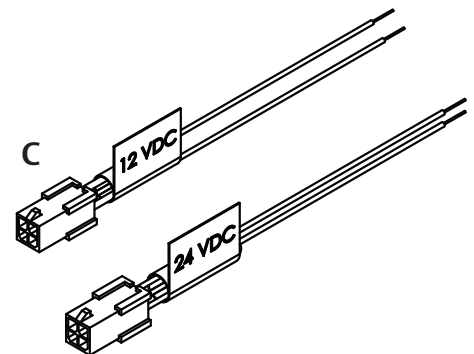
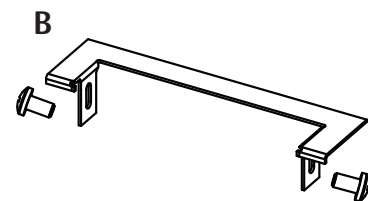
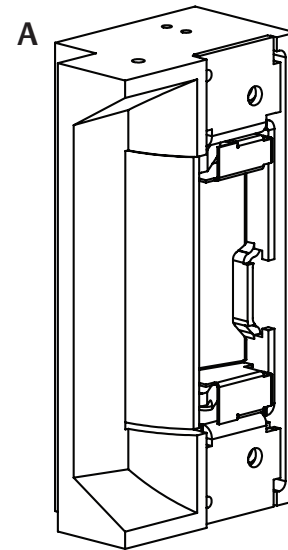

Installation



WARNING: Before connecting any device at the installation site, verify input voltage using a multimeter. Many power supplies and low voltage transformers operate at higher levels than listed. Any input voltage exceeding 10% of the solenoid rating may cause severe damage to the unit. Installation wiring for the product and wiring methods shall be in accordance with the National Electrical Code, ANSI/NFPA 70.

Preparing the Strike

For 12 VAC, 12 VDC, or 16 VAC, the Plug In Connector (pigtail) marked "12 VDC" should be used; for 24VAC or 24 VDC, the pigtail marked "24 VDC" should be used.

- 1 SELECT the appropriate plug in connector that matches system power and electrically CONNECT as shown in Diagram 1, "12 VDC to 24 VDC Conversion."

NOTE: BLACK wire of pigtail is NEGATIVE (-).

- 2 IF using optional Latchbolt Monitor (LBM), THEN COMPLETE wiring in accordance with Table 1, "Wiring (Monitored Version)".
- 3 VERIFY that the strike is in the correct mode of operation (Fail Secure or Fail Safe).
- 4 IF the 5000 | 5300 Series Electric Strike must be converted to Fail Safe mode, THEN CONVERT in accordance with Diagram 2, "Fail Safe Conversion".

Preparing the Frame

- 1 PREPARE the frame for lockset using appropriate cutout template, as shown (see page 4).

Finishing the Installation

- 1 CHOOSE the appropriate faceplate for the strike as shown (see page 4).
- 2 INSTALL faceplate on strike using 2x #8-32 x 1/2" flat head screws
- 3 CONNECT wires from the power source to the strike.
- 4 INSTALL the electric strike unit in jamb cutout, using 2X #12-24 x 1/2" Mounting Screws provided with the faceplate.

Wiring (Monitored Version)

Table 1: Latchbolt Monitor (LBM)

White	Common
Orange	Normally Open
Green	Normally Closed

NOTE: State as shown when door is open.

Diagram 1:
12 VDC to 24 VDC Conversion

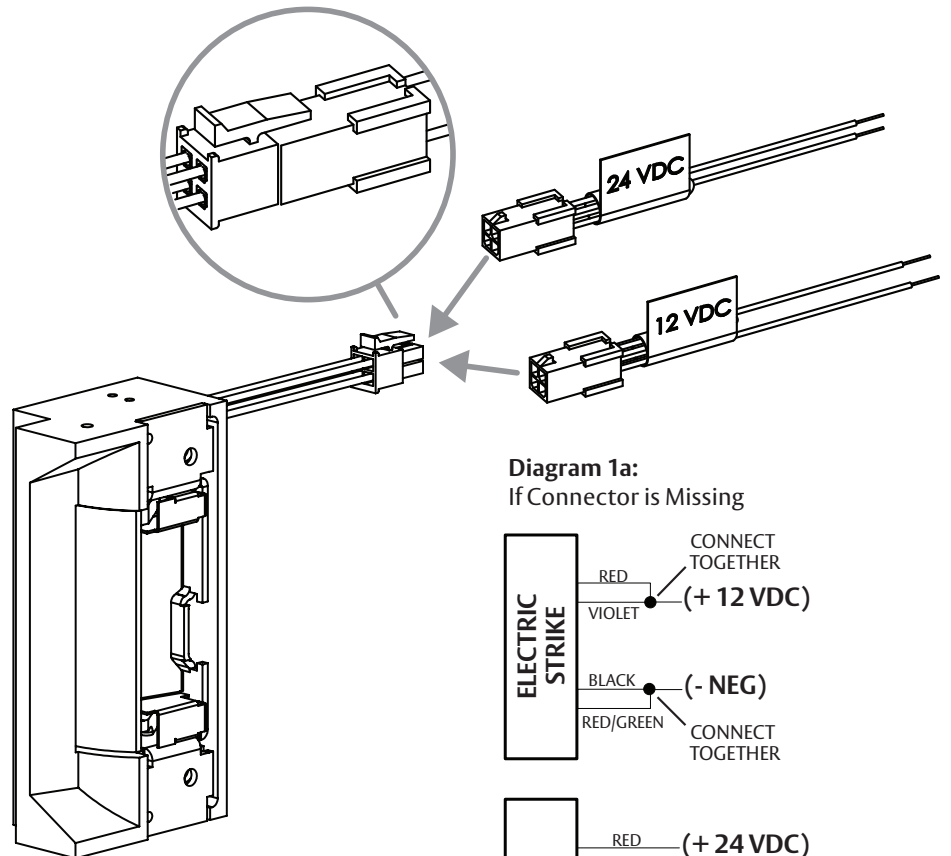
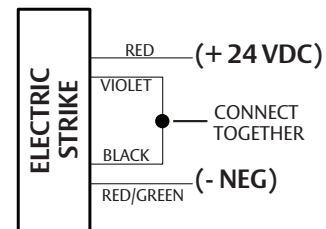
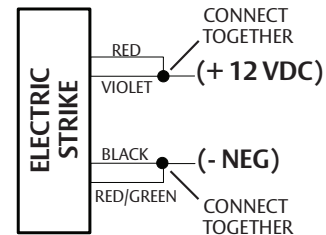

Diagram 1a:
If Connector is Missing



Converting the Operation Mode

This unit ships in Fail Secure mode. To convert to Fail Safe mode, perform the following instructions.

The system shall not be installed in the fail-secure mode unless permitted by local authority having jurisdiction and shall not interfere with the operation of Listed panic hardware.

- 1 LOOSEN the two #2-56 screws located on the back of the strike and slide them to fail safe position, as shown in Diagram 2, but DO NOT REMOVE them.
- 2 MOVE screws from the bottom of the hole (Fail Secure mode position) to the top hole (Fail Safe mode position).
- 3 TIGHTEN the bottom screw first (wire side), and THEN TIGHTEN the top screw.
- 4 VERIFY the strike is now in the Fail Safe operation mode.
- 5 IF the strike still operates as Fail Secure, THEN ENSURE the screws are fully seated in the top position.

NOTE: Fire rating only applies to Fail Secure Units. Conversion to Fail Safe negates fire rating on 5300.

Diagram 2: Fail Safe Conversion

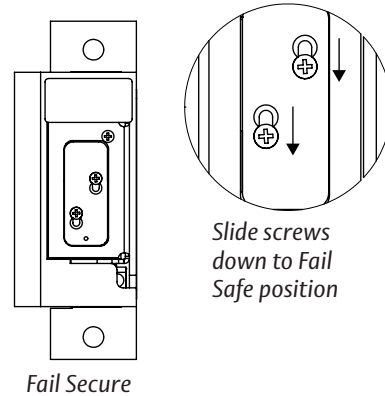

Diagram 3a: Fail Secure LBM Wiring Example

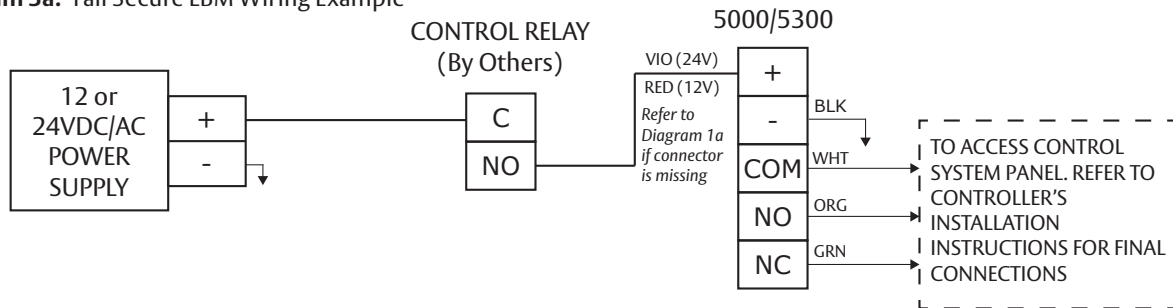
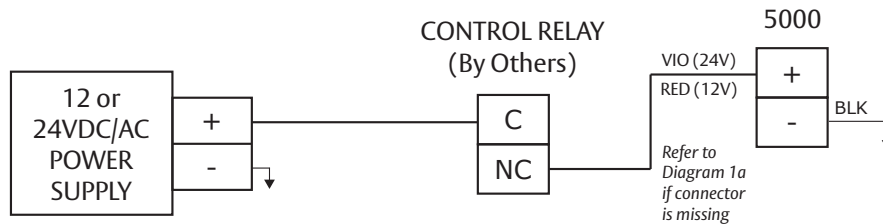

Diagram 3b: Fail Safe Wiring Example



Cutout Templates for Frame Preparation

Inches [Millimeters]

501 Faceplate Option

(4-7/8" x 1-1/4"), Square Corners and Flat Faceplate; Used with cylindrical locksets in ANSI metal jambs.

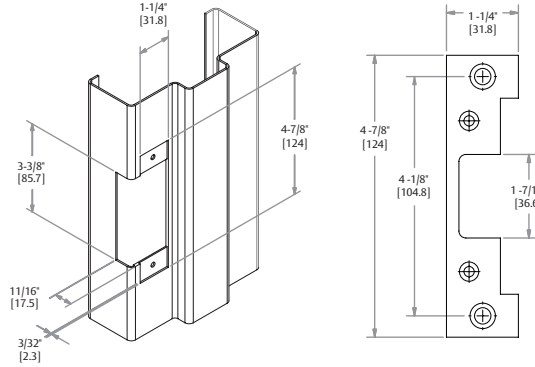

501A Faceplate Option

(4-7/8" x 1-1/4"), Radius Corners and Flat Faceplate; Used with cylindrical locksets or spring latches in aluminum frames.

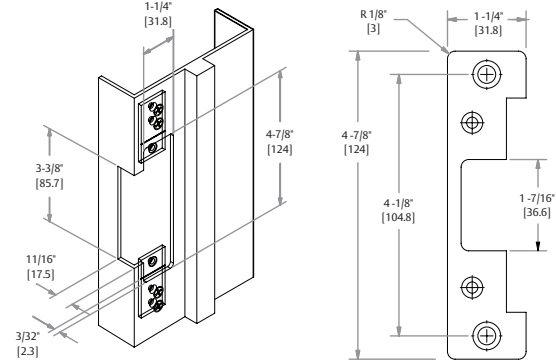

502 Faceplate Option

(7-15/16" x 1-7/16"), Radius Corners and Flat Faceplate; Used with cylindrical locksets or spring latches in aluminum frames.

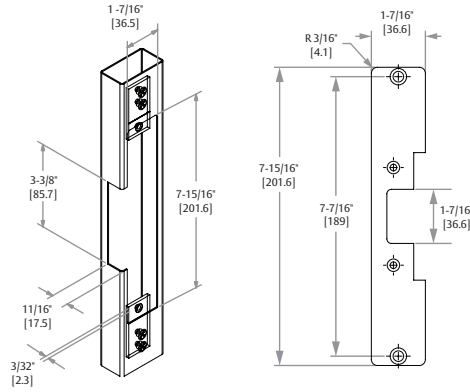

503 Faceplate Option

(6-7/8" x 1-1/4"), Radius Corners and Flat Faceplate; Used with cylindrical locksets or spring latches in aluminum frames.

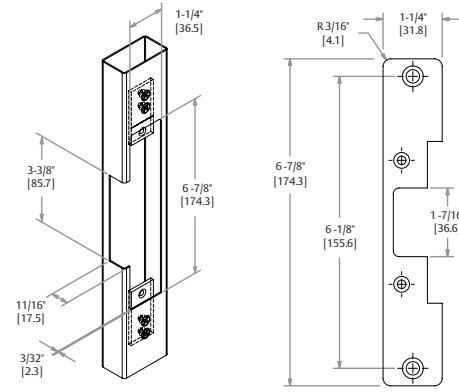

504 Faceplate Option

(10" x 1-3/8"), Radius Corners and Flat Faceplate; Used with cylindrical locksets; four-point mounting for wood installations.

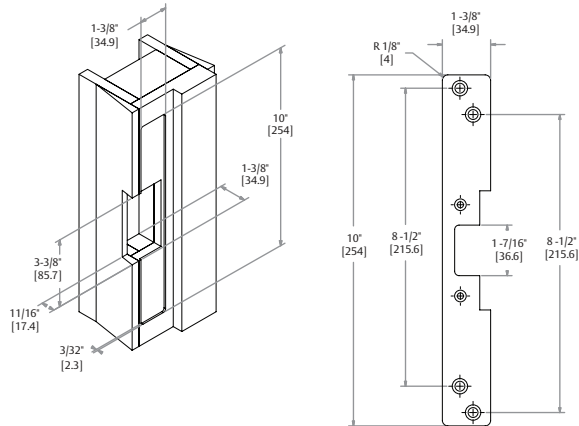

Note:

HESCUT-MTK Reusable metal template kit available for easier installation (sold separately).

Warranty For information on warranty coverage and replacement options, please visit [hesinnovations.com/warranty](https://www.hesinnovations.com/warranty)



techsupport.hes@assaabloy.com
hesinnovations.com | 800 626 7590

Printed in the U.S.A.
Patent pending and/or patent www.assaabloyds.com/patents
Copyright © 2025, Hanchett Entry Systems, Inc., an ASSA ABLOY Group company.
All rights reserved. Reproduction in whole or in part without the express written permission of Hanchett Entry Systems, Inc. is prohibited. 3019006.003_7